

WKE/G mit Passfederverbindung with keyway connection

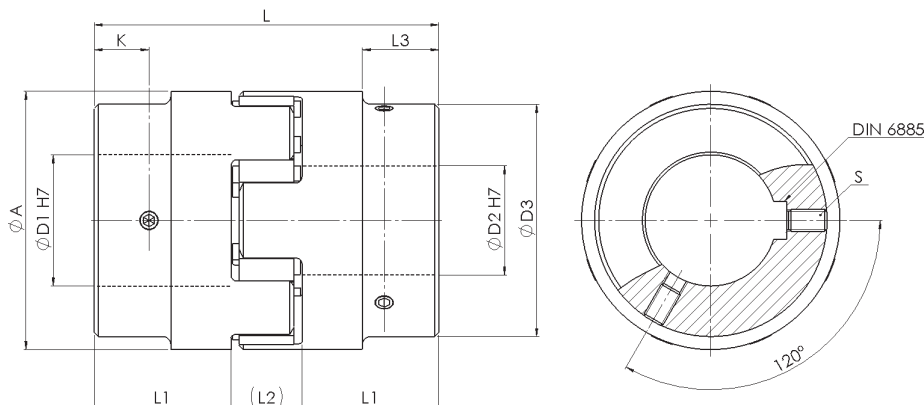

Material:
Nabe - Aluminium
ab Gr. 42 - Stahl

Standardzahnkranz:
92 ShA
Optional Zahnkranz:
64 ShD, 80 ShA, 98 ShA
Passfedernut ØD1 / ØD2:
Nach DIN 6885

Material:
Hub - aluminum
from size 42 - steel
Standard elastomer insert:
92 ShA
Optional elastomer insert:
64 ShD, 80 ShA, 98 ShA
Keyway ØD1 / ØD2:
Acc. to DIN 6885

WKE/G			Abmessungen Dimensions								ISO 4029	Technische Daten Technical Data			
Größe Size	TKN		L	ØA	ØD1 / ØD2	ØD3	L1	L2	L3	K	S	TA	J	n _{max}	M
	92 ShA	98 ShA													
	[Nm]		[mm]									[Nm]	[kg cm ²]	[min ⁻¹]	[kg]
5	0,5	0,9	15	10	2 - 6	-	5	5	-	2,5	1x M3	0,5	0,0004	47500	0,003
7	1,2	2	22	14	3 - 7	-	7	8	-	3,5	1x M3	0,5	0,002	35000	0,007
9	3	5	30	20	4 - 11	-	10	10	-	5	1x M4	1,5	0,011	24000	0,018
14	7,5	12,5	35	30	5 - 16	-	11	13	-	5	2x M4	1,5	0,064	16000	0,045
19	10	17	66	40	6 - 24	-	25	16	-	10	2x M5	2	0,37	12000	0,14
24	35	60	78	55	8 - 32	-	30	18	-	10	2x M5	2	1,71	8700	0,36
28	95	160	90	65	10 - 38	-	35	20	-	15	2x M8	10	3,7	7400	0,53
38	190	325	114	80	12 - 45	-	45	24	-	15	2x M8	10	11,02	6000	1,06
42	265	450	126	95	14 - 55	85	50	26	28	20	2x M8	10	49,6	5000	3,53
48	310	525	140	105	15 - 65	95	56	28	32	20	2x M8	10	99,08	4600	5,34
55	410	685	160	120	20 - 74	110	65	30	37	20	2x M10	17	161,61	4000	6,83
65	900	-	185	135	22 - 80	115	75	35	47	20	2x M10	17	257,6	3500	9,07

Massenträgheitsmoment und Masse sind mit dem größten Bohrungsdurchmesser gerechnet. Mass moment of inertia and mass are calculated with reference to the largest bore size.

Weitere technische Daten, siehe Seite 30. Further technical data, see page 30.

Laufend aktualisierte Daten finden Sie auf unserer Homepage. For continuously updated data please refer to our website.

Technische Daten	Technical Data
TKN - Drehmoment	TKN - Torque
TA - Anzugs-Drehmoment der Schraube	TA - Installation torque per screw
J - Massenträgheitsmoment	J - Mass moment of inertia
n _{max} - max. Drehzahl	n _{max} - max. speed
M - Masse	M - Mass

Bestellbeispiel / order example	WKE/G	19	12	16	92	SX
Modell / model						
Größe / size						
Bohrung ØD1 H7 / bore ØD1 H7						
Bohrung ØD2 H7 / bore ØD2 H7						
Zahnkranz / elastomer insert						
Sonderoption / special option						

